

4

3

2

1

FLS Style Valve Valve Size	Dimension				Ring Gasket R or RX	Weight (lbs)	Handwheel Dia. (in)
	A	B	C	D			
2 1/16" - 5,000 psi	14.625	26.75	8.50	2.09	24	182	14
2 9/16" - 5,000 psi	16.625	28.38	9.62	2.59	27	255	14
3 1/8" - 5,000 psi	18.625	30.20	10.50	3.22	35	360	18.5
4 1/16" - 5,000 psi	21.625	33.50	12.25	4.28	39	545	18.5

ITEM NO.	DESCRIPTION	QTY.
1	Handwheel	1
2	Retainer Pin	1
3	Stem Adapter	1
4	O Ring	1
5	Bearing Cap	1
6	Bearing Race	4
6	Thrust Bearing	2
7	Packing Gland Nut	1
8	Grease Injection Plug	1
9	Back-Up Ring	1
10	Stem Seal	1
11	Ring Gasket	1
12	Stem	1
13	Body GV	1
14	Seat	2
15	Retainer Plate	1
16	Hex Nut	8
17	Stud	8
18	Dowel Pin	1

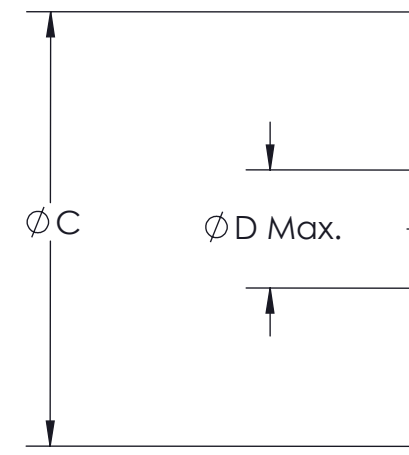
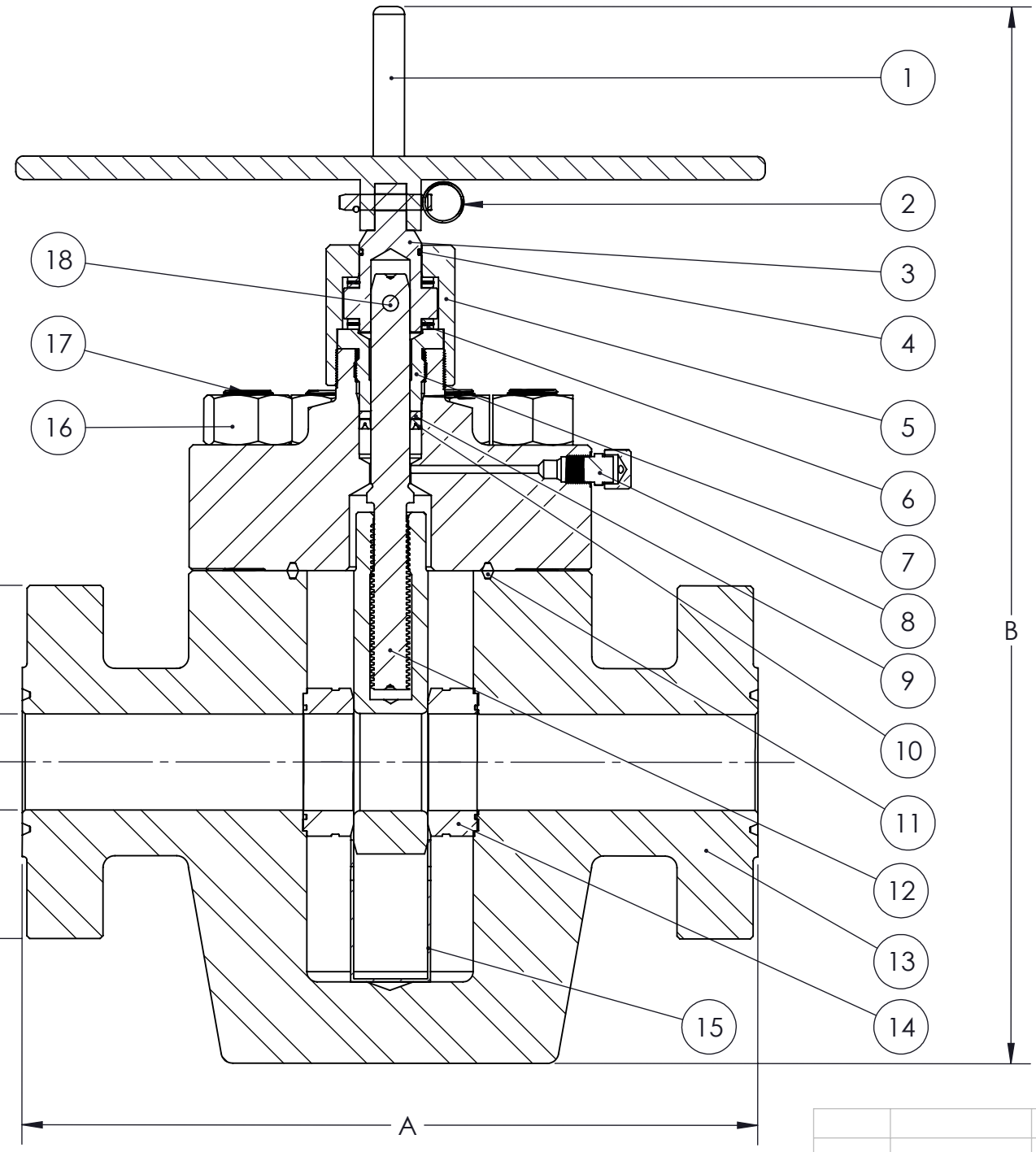
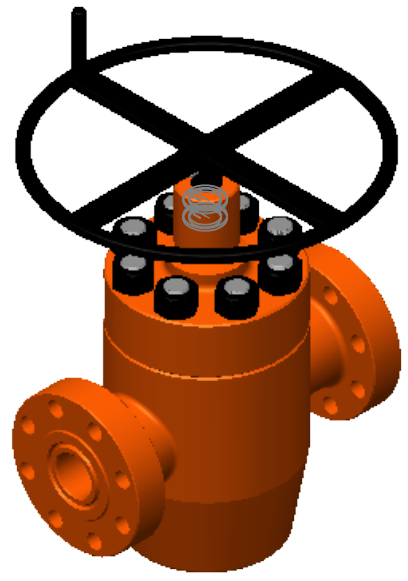

**PROPRIETARY AND CONFIDENTIAL**  
 THE INFORMATION CONTAINED IN THIS DRAWING IS THE SOLE PROPERTY OF HESHKA OIL. ANY REPRODUCTION IN PART OR AS A WHOLE WITHOUT THE WRITTEN PERMISSION OF HESHKA OIL IS PROHIBITED.

REV.	ECN Number	Date

UNLESS OTHERWISE SPECIFIED:  
 DIMENSIONS ARE IN INCHES  
 TOLERANCES:  
 FRACTIONAL: ±1/64"  
 ANGULAR: ±1/2 Degree  
 x.x ± .03  
 x.xx ± .01  
 x.xxx ± .005  
 Surface Finish 125RMS Unless Otherwise Noted  
 MATERIAL See Part Data Sheet  
 FINISH XXXXXXXX

NAME	DATE
DRAWN FBR	9/20/2019
CHECKED MJKP	9/26/2019
ENG APPR. MJKP	9/26/2019
MFG APPR.	
Q.A.	
COMMENTS:	

**HESHKA OIL**

TITLE: Gate Valve  
 2 1/16" thru 4 1/16" 5,000 psi  
 FLS STYLE  
 Data Sheet

SIZE <b>B</b>	DWG. NO. MKT-FLS_GV	REV <b>A</b>
SCALE: NTS	WEIGHT:	SHEET 1 OF 1

4

3

2

1