

Item #	Description	Qty.	Item #	Description	Qty.	Item #	Description	Qty.	Item #	Description	Qty.
1	BPV Coupling	1	7	HP 9/16" A/Clave Adapter	4	13	Blind Flange	1	19	Polished Rod Stop Collar	1
2	Yoke Body	2	8	Hex Nut B7	32	14	Swivel Lift Eye	1	20	Packing Set	2
3	9/16" A/Clave 2 way HP Valve	3	9	Stud B7	16	15	Ring Gasket	2	21	Cap Screw (Side Plate)	16
4	Dowel Pin	8	10	Spacer Spool 48"	1	16	Pressure Gage	1			
5	Packing Gland Nut	2	11	Polished Rod	1	17	9-1/16" HP Valve 3 Way	1			
6	Side Plate	2	12	No Go Coupling	1	18	HP Tubing	1			

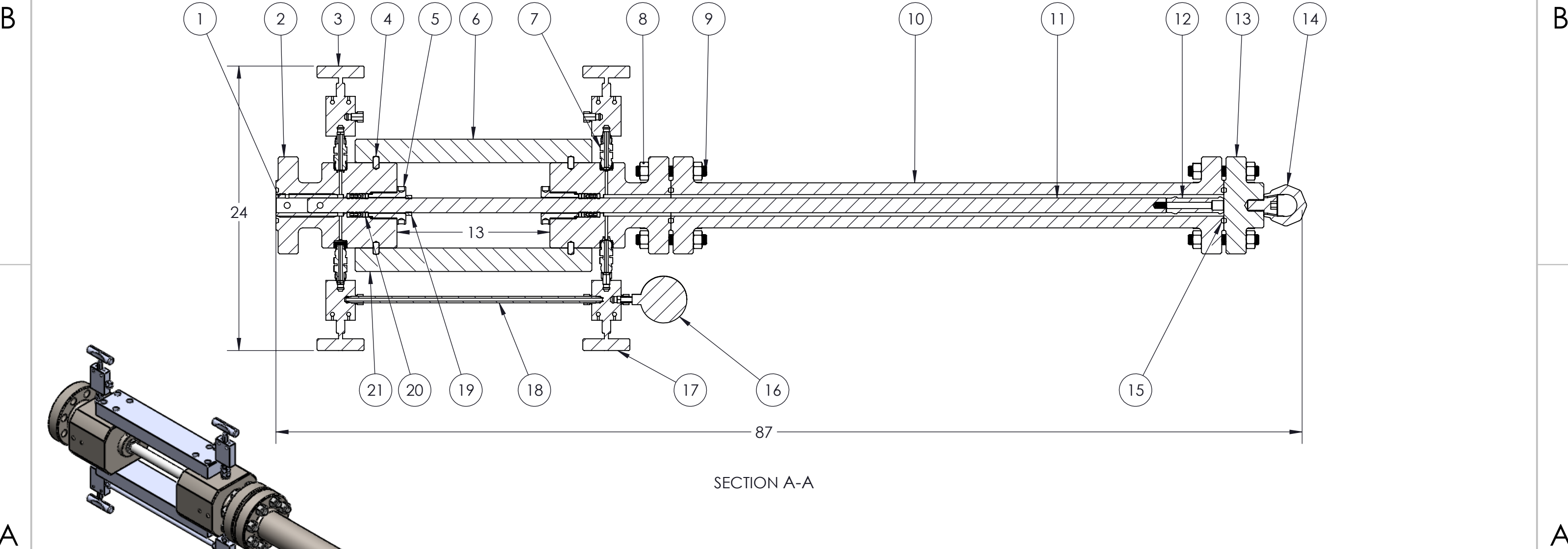

SECTION A-A

**PROPRIETARY AND CONFIDENTIAL**  
 THE INFORMATION CONTAINED IN THIS DRAWING IS THE SOLE PROPERTY OF HESHKA OIL. ANY REPRODUCTION IN PART OR AS A WHOLE WITHOUT THE WRITTEN PERMISSION OF HESHKA OIL IS PROHIBITED.

UNLESS OTHERWISE SPECIFIED:			NAME	DATE
DIMENSIONS ARE IN INCHES			DRAWN	MJKP 5/12/2020
TOLERANCES:			CHECKED	MP 5/12/2020
FRACTIONAL: ±1/64"			ENG APPR.	
ANGULAR: ±1/2 Degree			MFG APPR.	
x.x ± .03			Q.A.	
x.xx ± .01			COMMENTS:	
x.xxx ± .005				
Surface Finish 125RMS Unless Otherwise Noted				
(X.XXX) INDICATES CRITICAL DIMENSION TO BE INSPECTED				
MATERIAL				
NA				
FINISH				
DO NOT SCALE DRAWING				

		<b>HESHKA OIL</b>	
		<b>GA</b>	
<b>PBMO VR Lubricator 15ksi w/48" Stroke</b>			
SIZE	DWG. NO.	REV	
<b>B</b>	H05122020-003-GA	<b>A</b>	
SCALE: NTS	WEIGHT: 500lb	SHEET 1 OF 1	