

4

3

2

1

ITEM NO.	Description	Material **	QTY.
1	Body	AISI 4130; 17-4pH SS; Inconel 718	1
2	Seal Ring	HNBR or Viton	1
3	Plunger Assembly	AISI 4130; 17-4pH SS; Inconel 718 with HNBR or Viton Seals	1
4	O Ring	HNBR or Viton	1
5	Ball Retainer	High Density PolyEthylene	1
6	Retainer Nut	AISI 4130; 17-4pH SS; Inconel 718	1

** Other Materials Available on Request

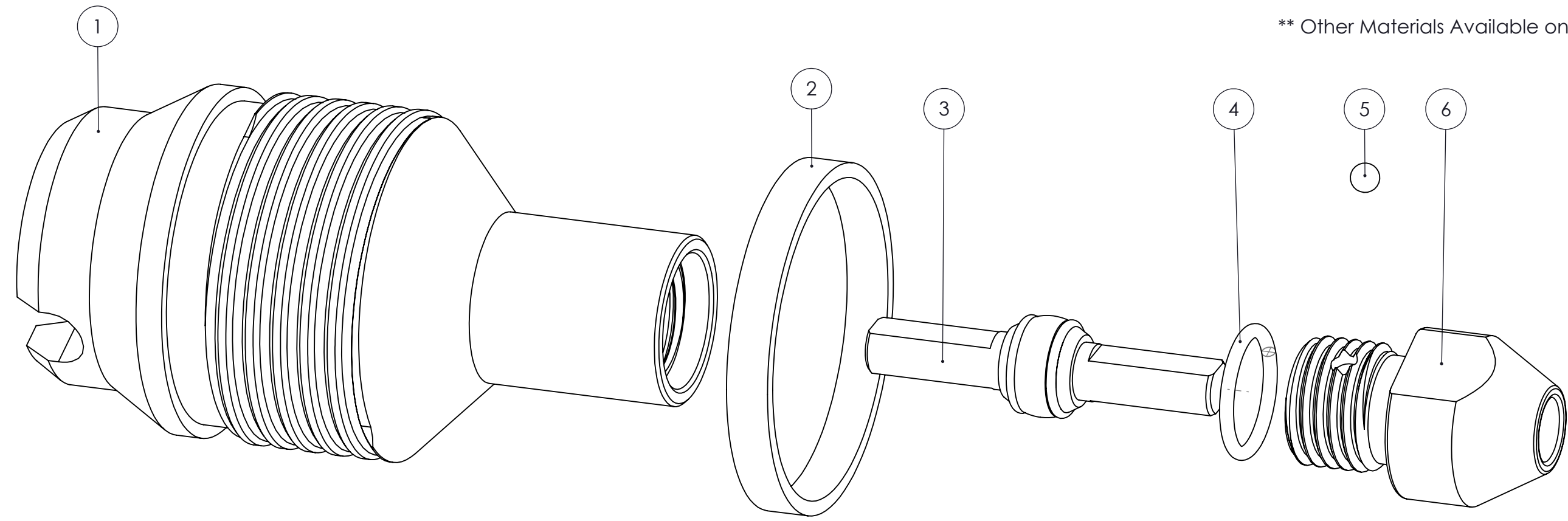

Technical Specifications	
Pressure Rating *	
<= 5"	15,000 psi
> 5"	10,000 psi
API	6A
Temperature Class	L-U
PR	2
NACE	H2S

* Pressure ratings are based on minimum material yield and assumes the Hanger is made from equivalent material and the hanger has the recommended number of threads machined in it

PROPRIETARY AND CONFIDENTIAL
 THE INFORMATION CONTAINED IN THIS DRAWING IS THE SOLE PROPERTY OF Heshka Oil LLC. ANY REPRODUCTION IN PART OR AS A WHOLE WITHOUT THE WRITTEN PERMISSION OF Heshka Oil LLC IS PROHIBITED.

UNLESS OTHERWISE SPECIFIED:			NAME	DATE	HESHKA OIL TITLE: GA TWC Valve Assembly	
DIMENSIONS ARE IN INCHES			DRAWN	FR		8/27/2019
TOLERANCES:			CHECKED	MJKP		9/4/2019
FRACTIONAL ± 1/64"			ENG APPR.	MP		9/4/2019
ANGULAR : ± 1/2 Degree			COMMENTS:			
X.X ± .030						
X.XX ± .010						
X.XXX ± .005						
Surface finish 125 Ra unless otherwise stated						
MATERIAL			See Table			
FINISH			Per Customer Requirements			
Revision			ECN Number			
Date			DO NOT SCALE DRAWING			
			SCALE: NTS WEIGHT:			
			SHEET 1 OF 1			
			SIZE DWG. NO. REV			
			B H041612-00-GA B			



4

3

2

1