

	Nominal Outlet Size in	Nominal Thread Size A	Threads per Inch TPI	Thread Major Diameter E	Overall Length D	SAE AS568A O-Ring Size No. J
Part Number	Tolerance		(Ref.)	+/- .004	+/- .030	NA
HPVR-134-DD	1-13/16	1-3/4	6	1.746	3.75	126
HPVR-200-DD	2-1/16	2	6	1.996	3.75	130
HPVR-250-DD	2-9/16	2-1/2	6	2.496	4.19	138
HPVR-300-DD	3-1/16	3	6	2.996	4.19	146

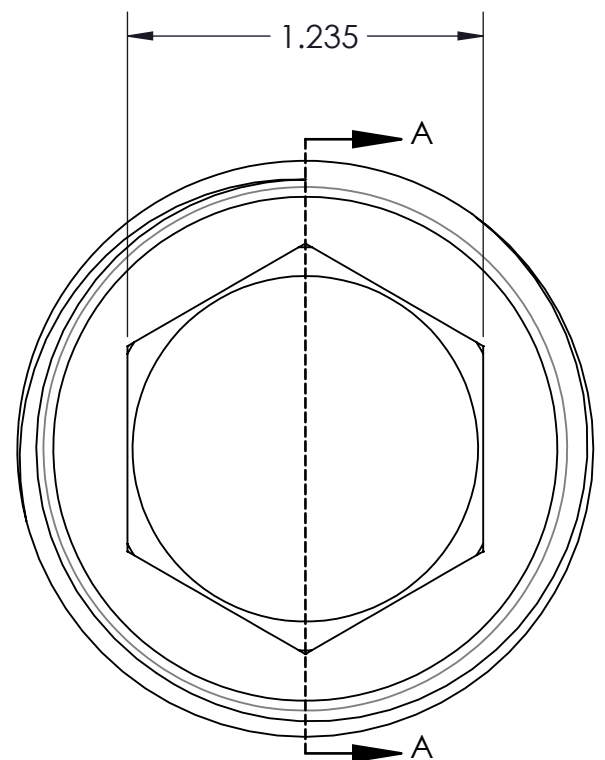
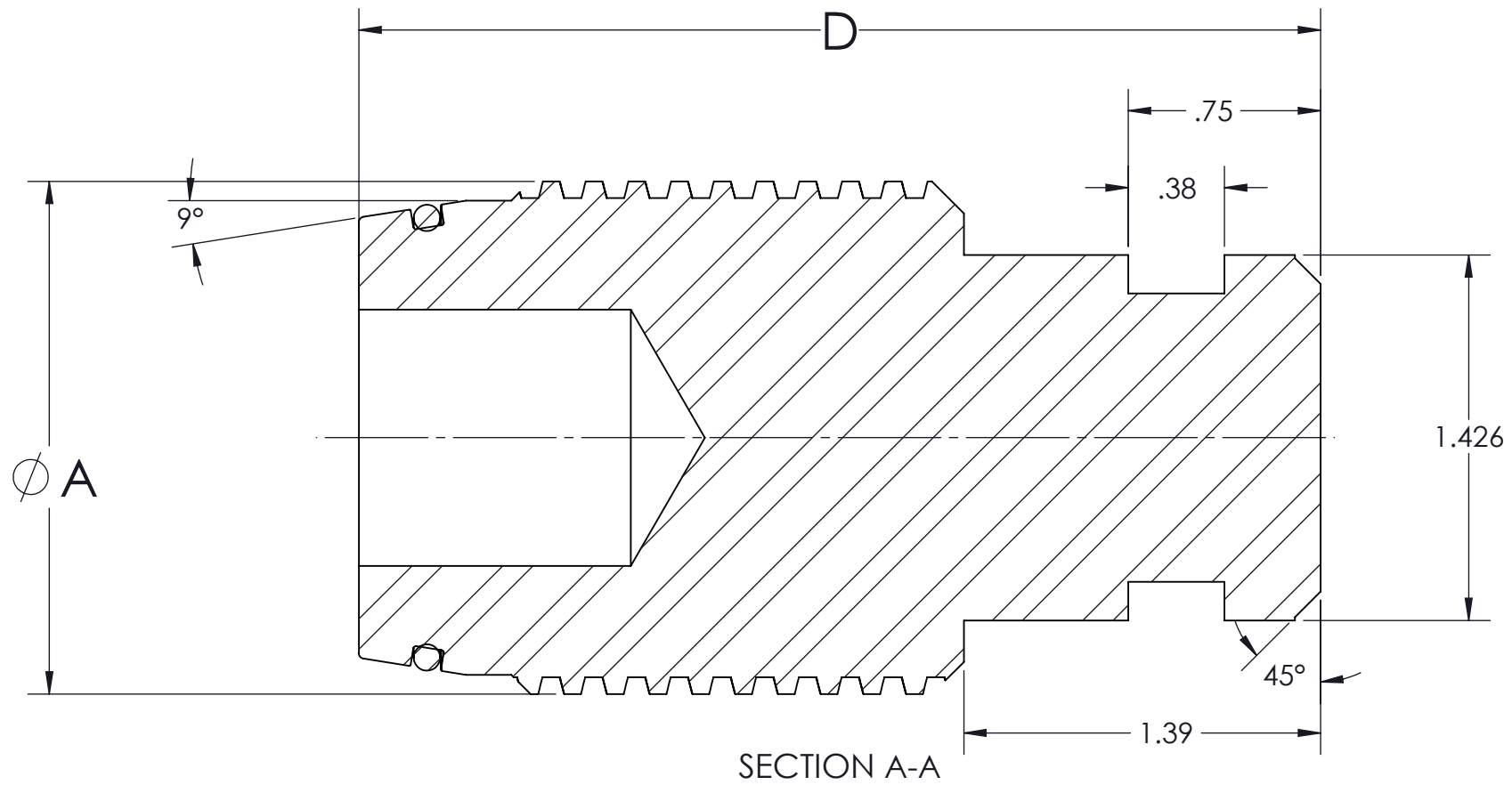

PROPRIETARY AND CONFIDENTIAL
 THE INFORMATION CONTAINED IN THIS DRAWING IS THE SOLE PROPERTY OF HESHKA OIL. ANY REPRODUCTION IN PART OR AS A WHOLE WITHOUT THE WRITTEN PERMISSION OF HESHKA OIL IS PROHIBITED.

REV.	ECN Number	Date
A	10054	1/2/2022

UNLESS OTHERWISE SPECIFIED:
 DIMENSIONS ARE IN INCHES
 TOLERANCES:
 FRACTIONAL: ±1/64"
 ANGULAR: ±1/2 Degree
 x.x ± .03
 x.xx ± .01
 x.xxx ± .005
 Surface Finish 125RMS Unless Otherwise Noted
 (X.XXX) INDICATES CRITICAL DIMENSION TO BE INSPECTED

MATERIAL: H4130S - NACE
 FINISH: DO NOT SCALE DRAWING

	NAME	DATE
DRAWN	MK	1/2/2022
CHECKED	AJ	1/2/2022
ENG APPR.	MJKP	1/2/2022
MFG APPR.		
Q.A.		
COMMENTS:		

HESHKA OIL

TITLE: **GA**
HP VR Plug
15,000 - 20,000 psi

SIZE B	DWG. NO. HPVR-XXX-XX-GA	REV A
SCALE: NTS	WEIGHT:	SHEET 1 OF 1