

4

3

2

1

	Nominal Outlet Size	Nominal Thread OD A	Threads Per Inch TPI	Thread Type	Overall Length of Plug F
Part Number	Tolerance		(REF.)	NA	+/- .03
VR-114-LP-DD	1- 13/16	1.660	11-1/2	Line Pipe	2.84
VR-112_SV-DD	2-1/6	1.900	11-1/2	Sharp Vee	3.16
VR-238-SV-DD	2-9/16	2.375	11-1/2	Sharp Vee	3.41
VR-278-SV-DD	3-1/8	2.875	11-1/2	Sharp Vee	3.84
VR-312_SV-DD	4-1/16	3.500	11-1/2	Sharp Vee	4.09

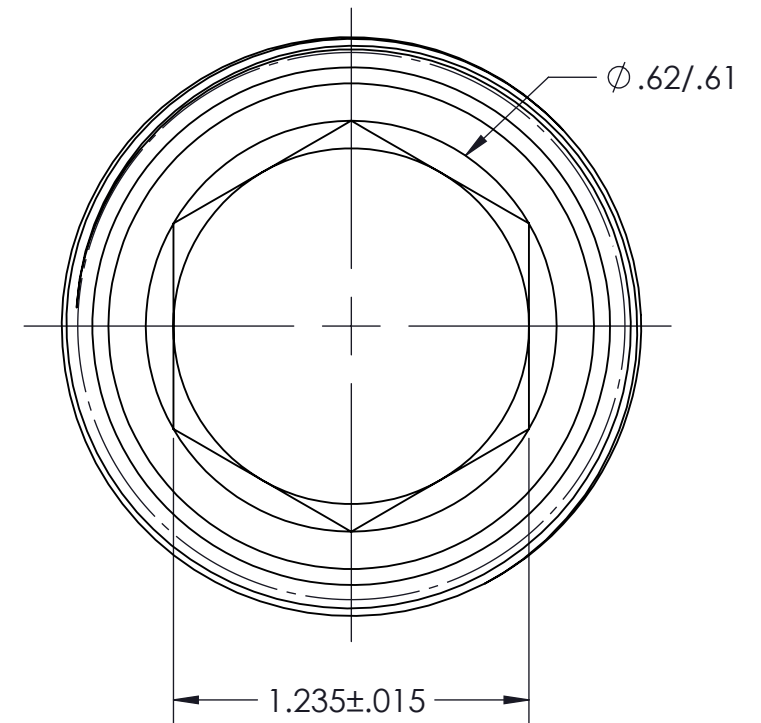
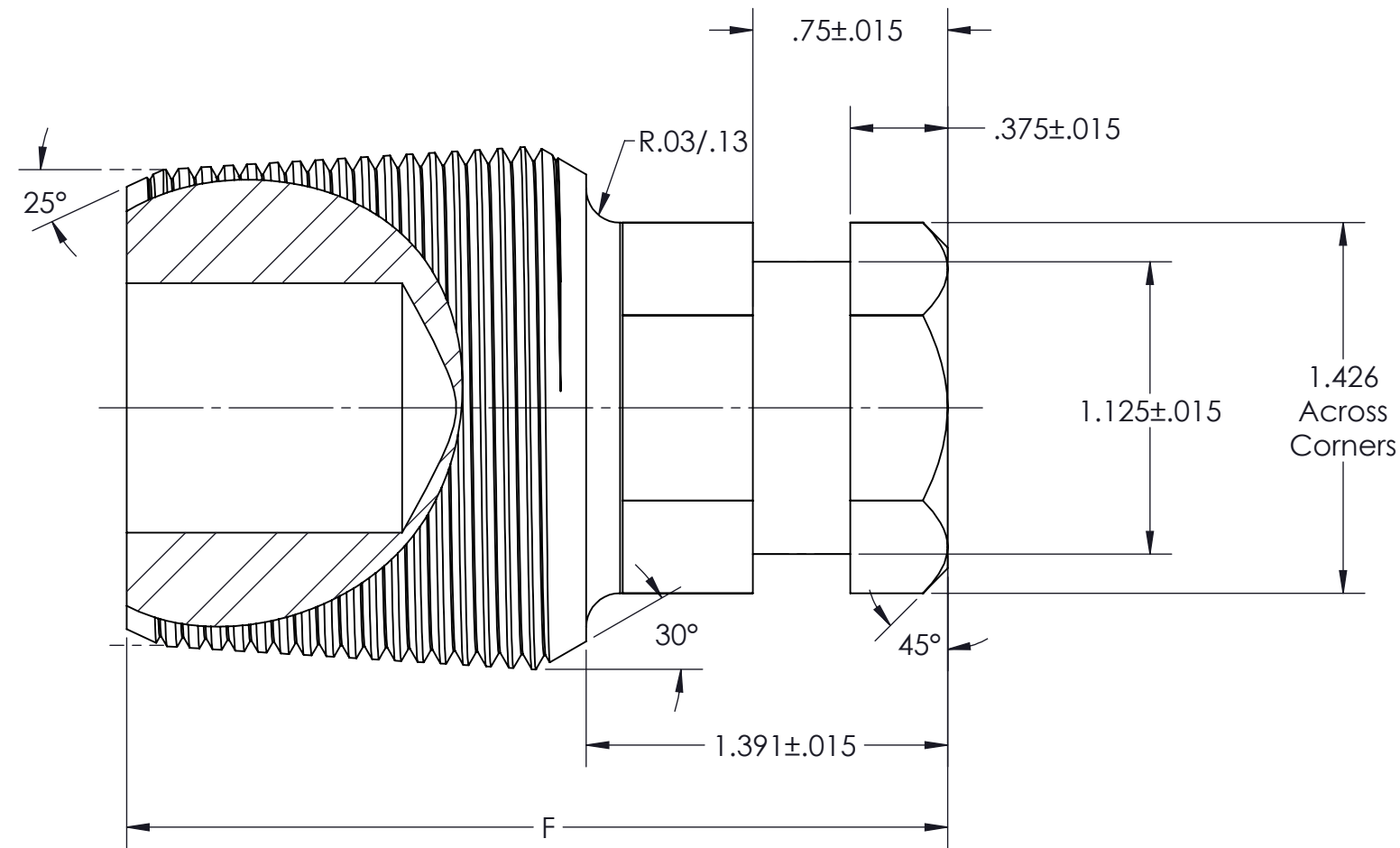

PROPRIETARY AND CONFIDENTIAL
THE INFORMATION CONTAINED IN THIS DRAWING IS THE SOLE PROPERTY OF HESHKA OIL. ANY REPRODUCTION IN PART OR AS A WHOLE WITHOUT THE WRITTEN PERMISSION OF HESHKA OIL IS PROHIBITED.

REV.	ECN Number	Date
A	10053	1/2/2020

UNLESS OTHERWISE SPECIFIED:

DIMENSIONS ARE IN INCHES
TOLERANCES:
FRACTIONAL: $\pm 1/64$ "
ANGULAR: $\pm 1/2$ Degree
x.x $\pm .03$
x.xx $\pm .01$
x.xxx $\pm .005$
Surface Finish 125RMS Unless Otherwise Noted

MATERIAL
H4130S Per NACE
FINISH

DO NOT SCALE DRAWING

	NAME	DATE
DRAWN	FBR	1/2/2020
CHECKED	MJKP	1/2/2020
ENG APPR.	MJKP	1/2/2020
MFG APPR.		
Q.A.		

COMMENTS:

HESHKA OIL

TITLE:
GA- VR Plug
2,000psi,3,000psi, 5,000psi
and 10,000psi

SIZE	DWG. NO.	REV
B	VR-XXX-XX-GA	A

SCALE: NTS WEIGHT: NA SHEET 1 OF 1

4

3

2

1