

ITEM NO.	DESCRIPTION	QTY.
1	1/2 NPT Quick Connect F	2
2	1/2 NPT x 1/2 NPT 90° Elbow	2
3	Nipple 1/2 x 1/2 NPT 2.5LG	2
4	Retainer Ring 10.325" OD	1
5	O-Ring #374	2
6	Actuator Plate	1
7	Piston	1
8*	Actuator Body	1
9	O-Ring #218	2
10**	O-Ring #241	1
11**	Backup Ring #241	1
12	O-Ring #226	1
13	Backup Ring #226	2
14*	Actuator Rod	1
15	1/2 Lock Washer	1
16	Rear Retainer	1
17	Gate	1
18	Front Retainer	1
19	1/2-13 UN 2B Hex Nut	1
20	O-Ring #342	2
21	Backup Ring #342	2
22	Seat	1
23	Wear Sleeve	1
24*	Body	1
25	O-Ring #214	2
26	3/4-10 UN 2B Hex Nut	1
27	3/4 Washer	1

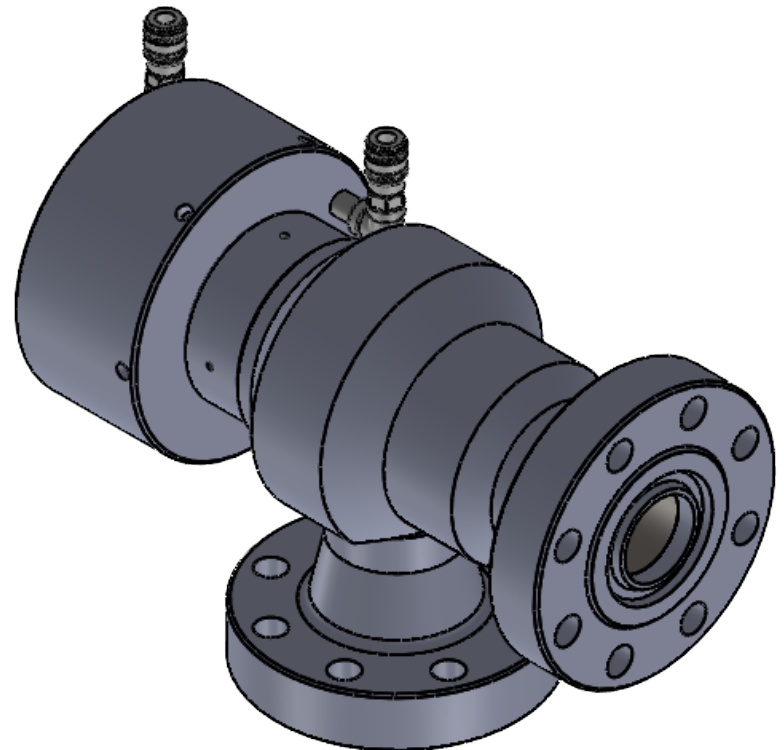

*These parts may change depending on the assemblies rated pressure
 **The number of parts used is doubled for the 15k rated assembly

PROPRIETARY AND CONFIDENTIAL
 THE INFORMATION CONTAINED IN THIS DRAWING IS THE SOLE PROPERTY OF HESHKA OIL. ANY REPRODUCTION IN PART OR AS A WHOLE WITHOUT THE WRITTEN PERMISSION OF HESHKA OIL IS PROHIBITED.

REV.	ECN Number	Date
A	10254	12/9/2021

UNLESS OTHERWISE SPECIFIED:
 DIMENSIONS ARE IN INCHES
 TOLERANCES:
 FRACTIONAL: ±1/64"
 ANGULAR: ±1/2 Degree
 x.x ±.03
 x.xx ±.01
 x.xxx ±.005
 Surface Finish 125RMS Unless Otherwise Noted
 (X.XXX) INDICATES CRITICAL DIMENSION TO BE INSPECTED

MATERIAL: NA
 FINISH: NA
 DO NOT SCALE DRAWING

	NAME	DATE
DRAWN	AJ	12/9/2021
CHECKED	MJKP	12/9/2021
ENG APPR.	MP	12/9/2021
MFG APPR.		
Q.A.		
COMMENTS:		

HESHKA OIL

TITLE: **CIW Drilling Choke GA**

SIZE: **B** DWG. NO.: H12092021-004 REV: **A**

SCALE: NTS WGT: NA SHEET 1 OF 1