

4

3

2

1

Item #	Description	Qty.
1	Plug 1502 Weco	1
2	Retainer Ring	2
3	Nut 1502 Weco	2
4	Seal Ring	2
5	No Go	1
6	Spool	1
7	Segmented Lock Ring	1
8	Upper Yoke	1
9	Back UP Ring	4
10	Seal Assembly	2
11	Gland Nut	2

Item #	Description	Qty.
12	Side Plate	2
13	Cap Screw	8
14	Dowel Pin	4
15	Lower Yoke	1
16	Polished Rod	1
17	Retainer Ring	1
18	Segmented Lock Ring	1
19	Slik Connect Nut	1
20	Dowel Pin	1
21	Socket Set Screw	1
22	Connector Coupling	1

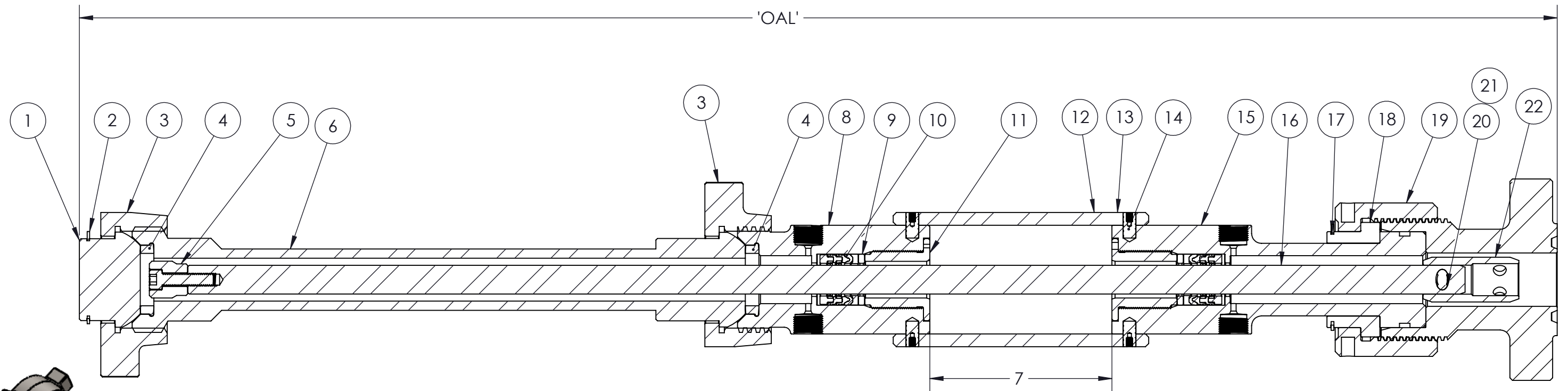

Size	# of Valves	Stroke (in)	OAL (in)	Weight (lbs)
1-13/16 - 10Ksi	1	24	58	183
1-13/16 - 10Ksi	2	48	82	216
2-1/16 - 10Ksi	1	24	58	183
2-1/16 - 10Ksi	2	48	82	216

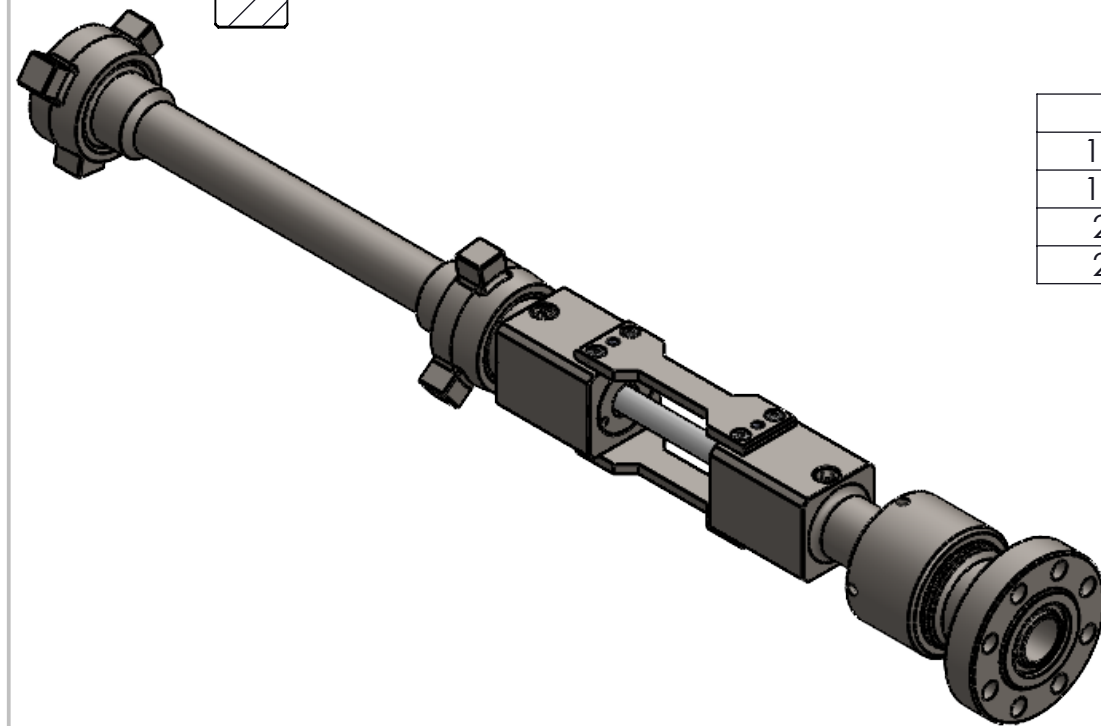

PROPRIETARY AND CONFIDENTIAL

THE INFORMATION CONTAINED IN THIS DRAWING IS THE SOLE PROPERTY OF HESHKA OIL. ANY REPRODUCTION IN PART OR AS A WHOLE WITHOUT THE WRITTEN PERMISSION OF HESHKA OIL IS PROHIBITED.

REV.	ECN Number	Date

UNLESS OTHERWISE SPECIFIED:

DIMENSIONS ARE IN INCHES
 TOLERANCES:
 FRACTIONAL $\pm 1/64"$
 ANGULAR: $\pm 1/2$ Degree
 x.x $\pm .03$
 x.xx $\pm .01$
 x.xxx $\pm .005$
 Surface Finish 125RMS Unless
 Otherwise Noted
 (X.XXX) INDICATES CRITICAL
 DIMENSION TO BE INSPECTED

MATERIAL

FINISH

DO NOT SCALE DRAWING

	NAME	DATE
DRAWN	MJKP	4/28/2021
CHECKED		
ENG APPR.		
MFG APPR.		
Q.A.		
COMMENTS:		



HESHKA OIL

TITLE:

GA

VR Lubricator

1-13/16" & 2-1/16"-10Ksi

SIZE DWG. NO.

B H04282021-001-GA

REV

A

SCALE: NTS WEIGHT:

SHEET 1 OF 1

4

3

2

1